

**VICOR CONFIDENTIAL**

THIS DOCUMENT AND THE DATA DISCLOSED HEREIN OR HEREWITH IS NOT TO BE REPRODUCED, USED, OR DISCLOSED IN WHOLE OR IN PART TO ANYONE WITHOUT PERMISSION OF VICOR CORP.

| REV. | DESCRIPTION          | DATE        | APVD |
|------|----------------------|-------------|------|
| 1    | Released per E080380 | JS 02-28-08 | REJH |

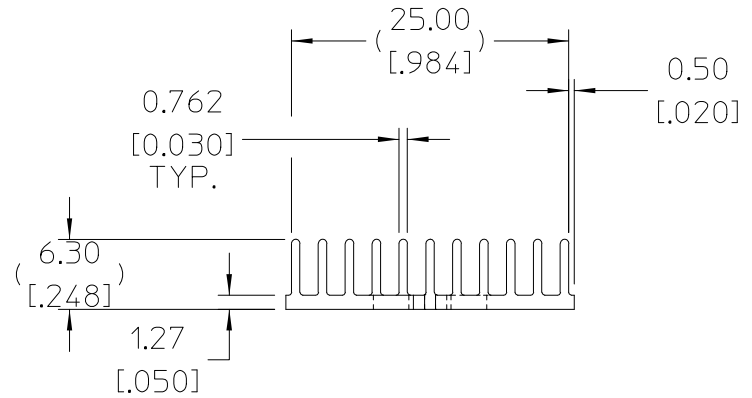
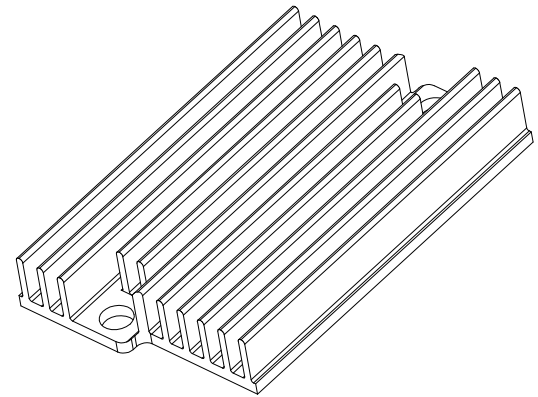
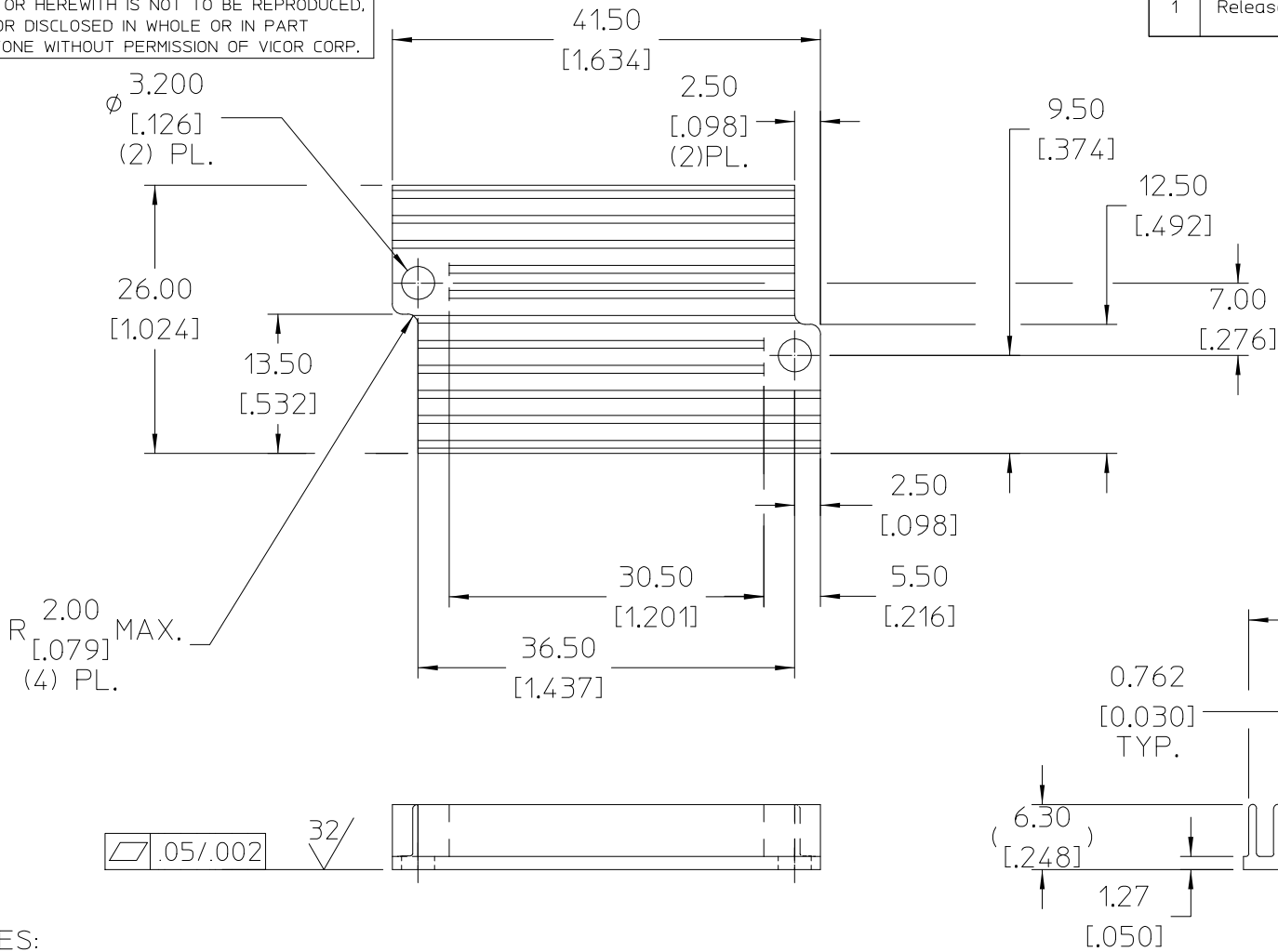

**NOTES:**

1. MAKE FROM VICOR PART NO. 29804.
2. FINISH: ELECTROLESS NICKEL PLATE PER ASTM B607-91, THICKNESS .000120" TO .000300" (3 TO 8μM)
3. REMOVE ALL BURRS AND SHARP EDGES.
4. RoHS COMPLIANT, LEAD FREE PER CST-0001 LATEST REVISION.

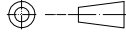
|  |                  |   |                 |          |
|--|------------------|---|-----------------|----------|
| DRAWN BY<br><i>R.E.J.Hickey</i>  | DATE<br>08/09/07 | <br><b>HEATSINK, CONDUCTIVE,<br/>6.3MM LF PUSH PIN</b> |                 |          |
| <small>UNLESS OTHERWISE SPECIFIED<br/>DIMENSIONS ARE MM (INCH)-<br/>TOLERANCES ARE:<br/>DECIMALS      ANGLES<br/>.XX = ±0.25 [01]    ±1°<br/>.XXX = ±0.127 [005]</small> |                  |   |                 |          |
| THIRD ANGLE PROJECTION<br>  | SIZE<br>B        | FSCM NO.<br>67131   | DWG NO<br>34071 | REV<br>1 |
| DO NOT SCALE DRAWING   | SCALE<br>2:1     | SHEET 1 OF 1  |                 |          |